

grande
brio
RIDE ON 75



INNOVATION IN CLEANING EQUIPMENT
TSM

grande brio

RIDE ON 75

550

650

800

Pista di pulizia / Scrubbing path	mm	550	650	800
Larghezza tergipavimento / Squeegee width	mm	650	750	850
Rendimento orario / Coverage performance	m ² /h	3000	3250	4000
Tempo di lavoro / Working time	h	> 3h	> 3h	> 3h
Serbatoio soluzione / Solution tank	l	75	75	75
Serbatoio recupero / Recovery tank	l	80	80	80
Diametro spazzole / Brush size	mm	2 x 290	4 x 180	4 x 205
Motore spazzole / Brush motor	W	2 x 200	4 x 100	4 x 200
Pressione spazzole / Brush pressure	kg	20	28	35
Motore trazione / Traction motor	W	450	700	700
Motore aspirazione / Vacuum motor	W	3 stages 530	3 stages 530	3 stages 530
Tensione di alimentazione / Voltage	V	24	24	24
Batterie (DIN) / Battery capacity (DIN)	A (5h)	150 (Wet)	150 (Wet)	150 (Wet)
Comparto batterie (L x L x H) / Batt. comp. (L x W x H)	mm	400 x 420 x 325	400 x 420 x 325	400 x 420 x 325
Caricabatterie a bordo / Battery charger	A/h	20	20	20
Peso senza (con) batterie / Weight without (with) batteries	kg	143 [220]	153 [230]	163 [240]
Dimensioni (L x L x H) / Dimensions (L x W x H)	mm	1150 x 780 x 1300	1150 x 780 x 1300	1150 x 780 x 1300

550

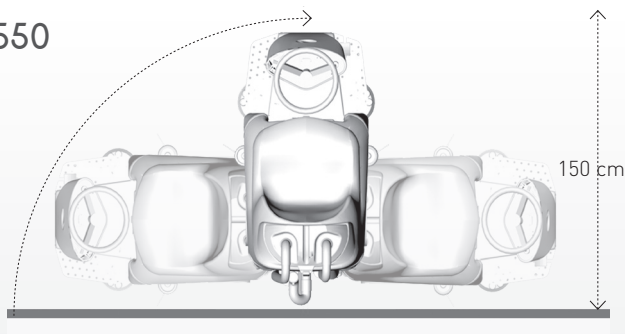

650-800

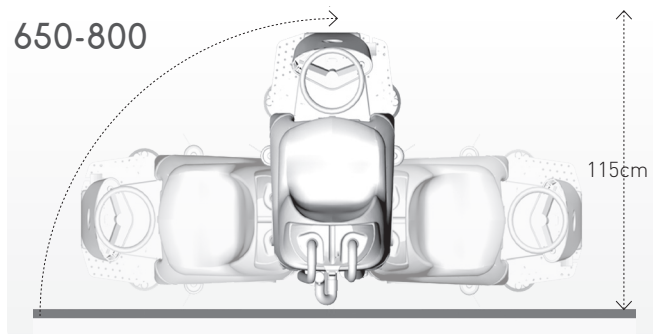

grande brío

RIDE ON 75

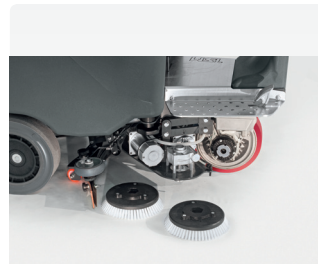
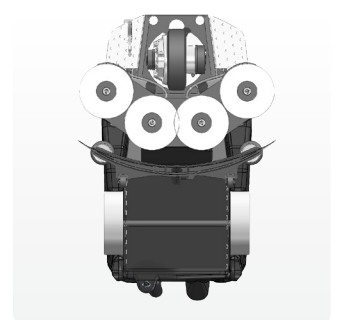
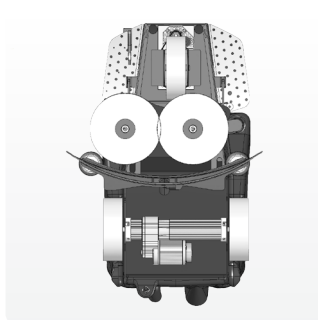

It's time to step forward and face the world's challenge. It's time for GRANDE BRIO

The conquest of simplicity



TSM - Technological Systems by Moro Srl

Via Fratelli Zambon, 9 - 33080 Fiume Veneto (PN) - Italy

Tel. +39.0434.564167 - Fax +39.0434.954069

www.tsmitaly.com - marketing@tsmitaly.com

 - [tsmitaly](https://www.youtube.com/tsmitaly) -

INNOVATION IN CLEANING EQUIPMENT
TSM

