

grande
brio
RIDE ON 145



grande briio

RIDE ON 145

850

1000

| | | | |
|---------------------------------------------------------|-------------------|-------------------|-------------------|
| Pista di pulizia / Pista de limpieza | mm | 850 | 1000 |
| Larghezza tergipavimento / Anchura boquilla aspiración | mm | 950 | 1100 |
| Rendimento orario / Rendimiento horario | m ² /h | 5100 | 6000 |
| Tempo di lavoro / Tiempo de trabajo | h | > 5h | > 5h |
| Serbatoio soluzione / Tanque de agua limpia | l | 145 | 145 |
| Serbatoio recupero / Tanque de agua sucia | l | 160 | 160 |
| Diametro spazzole / Diámetro cepillos | mm | 2 x 425 | 2 x 500 |
| Motore spazzole / Motor cepillos | W | 2 x 500 | 2 x 650 |
| Pressione spazzole / Presión cepillos | kg | 0-55 | 0-65 |
| Motore trazione / Motor tracción | W | 600 | 600 |
| Motore aspirazione / Motor aspiración | W | 3 stages 490 | 3 stages 490 |
| Tensione di alimentazione/ Tensión | V | 24 | 24 |
| Batterie (DIN) / Baterías (DIN) | A (5h) | 320 (Wet) | 320 (Wet) |
| Comparto batterie (LxLxH) / Compartim. baterías (LxAxA) | mm | 617x210x430 (x2) | 617x210x430 (x2) |
| Caricabatterie / Cargador baterías | A/h | 25 | 25 |
| Peso senza (con) batterie / Peso sin (con) baterías | kg | 262 | 282 |
| Dimensioni (LxLxH) / Dimensiones (LxAxA) | mm | 1580 x 850 x 1520 | 1580 x 850 x 1520 |

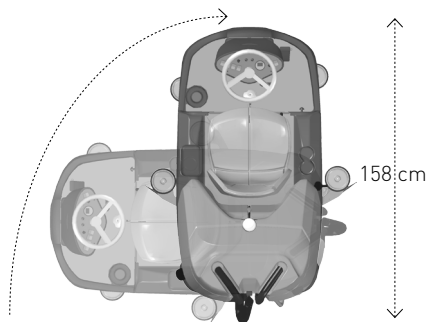

grande
brio
RIDE ON 145



Es la hora de pensar más allá y enfrentar los retos del mundo.
Es la hora de GRANDE BRIO

La conquista de la simplicidad



TSM - Technological Systems by Moro Srl

Via Fratelli Zambon, 9 - 33080 Fiume Veneto (PN) - Italy

Tel. +39.0434.564167 - Fax +39.0434.954069

www.tsmitaly.com - marketing@tsmitaly.com

 - [tsmitaly](https://www.youtube.com/tsmitaly) -

INNOVATION IN CLEANING EQUIPMENT

TSM

