

cubomatic¹⁸⁰ electric



INNOVATION IN CLEANING EQUIPMENT

TSM

180

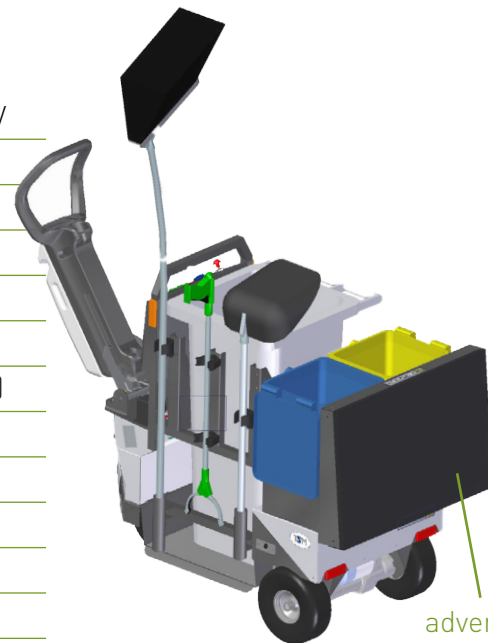

advertising
TV screen

Alimentation / Runs on	-	Battery, 24 V
Capacité bac principale / Main hopper capacity	l	120
Capacité bacs secondaires / Secondary bins capacity	l	2 x 30
Temps travail / Working time	h	~ 8
Puissance total / Total power	W	450
Chargeur batteries à bord / On board battery charger	A/h	5
Capacité batteries maximum / Max batteries capacity	A (1h)	28 (Lithium)
Pente maximale / Maximum gradient	%	20
Vitesse maximale / Maximum speed	Km/h	6
Rayon de braquage / Steering range	mm	2600
Frein / Brake	-	electric
Niveau bruit / Noise level	Db (A)	68
Dimensions machine (LxlxH) / Dimensions (LxWxH)	mm	1240x630x1400
Poids sans batteries / Weight without batteries	Kg	325
Emballage (LxlxH) / Packaging (LxWxH)	mm	1200x800x1590

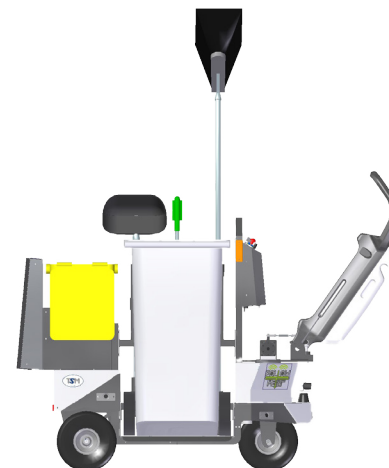
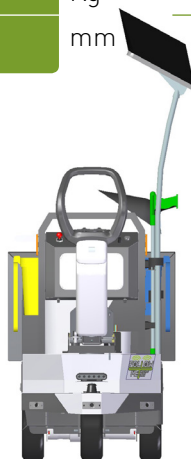

TSM - Technological Systems by Moro Srl

Via Fratelli Zambon, 9 - 33080 Fiume Veneto (PN) - Italy

Tel. +39.0434.564167 - Fax +39.0434.954069

www.tsmitaly.com - marketing@tsmitaly.com

 - tsmitaly -

INNOVATION IN CLEANING EQUIPMENT

